



Sacramento Area Council of Governments
1415 L Street, Suite 300
Sacramento, CA 95814

Project Level Conformity Group Meeting

Wednesday, March 12, 2025, 10:30 a.m. to 12:00 p.m.

Meeting Information

Remote Participation Instructions

- [Join by computer or smart device](#)
- Or dial in using your phone:
 - Dial-in #: (877) 853-5257 or (888) 475-4499
 - Meeting ID: 831 0371 1286

Agenda

1. Welcome and Introductions
2. Consultation to Determine Project of Air Quality Concern (POAQC) Status
 - a. White Rock Rd - .5 Mile East of Rancho Cordova Parkway to Rio Del Oro Parkway (SAC25272)
3. Review of Regional Conformity Exemption Status
4. Next Steps

SACOG POAQC Coordinator:

Jackie Kahrs

jkahrs@sacog.org

White Rock Rd - .5 Mile East of RC Parkway to Rio Del Oro Parkway



March 12, 2025

Project Level Conformity Group Meeting



White Rock Road Project

Project Location

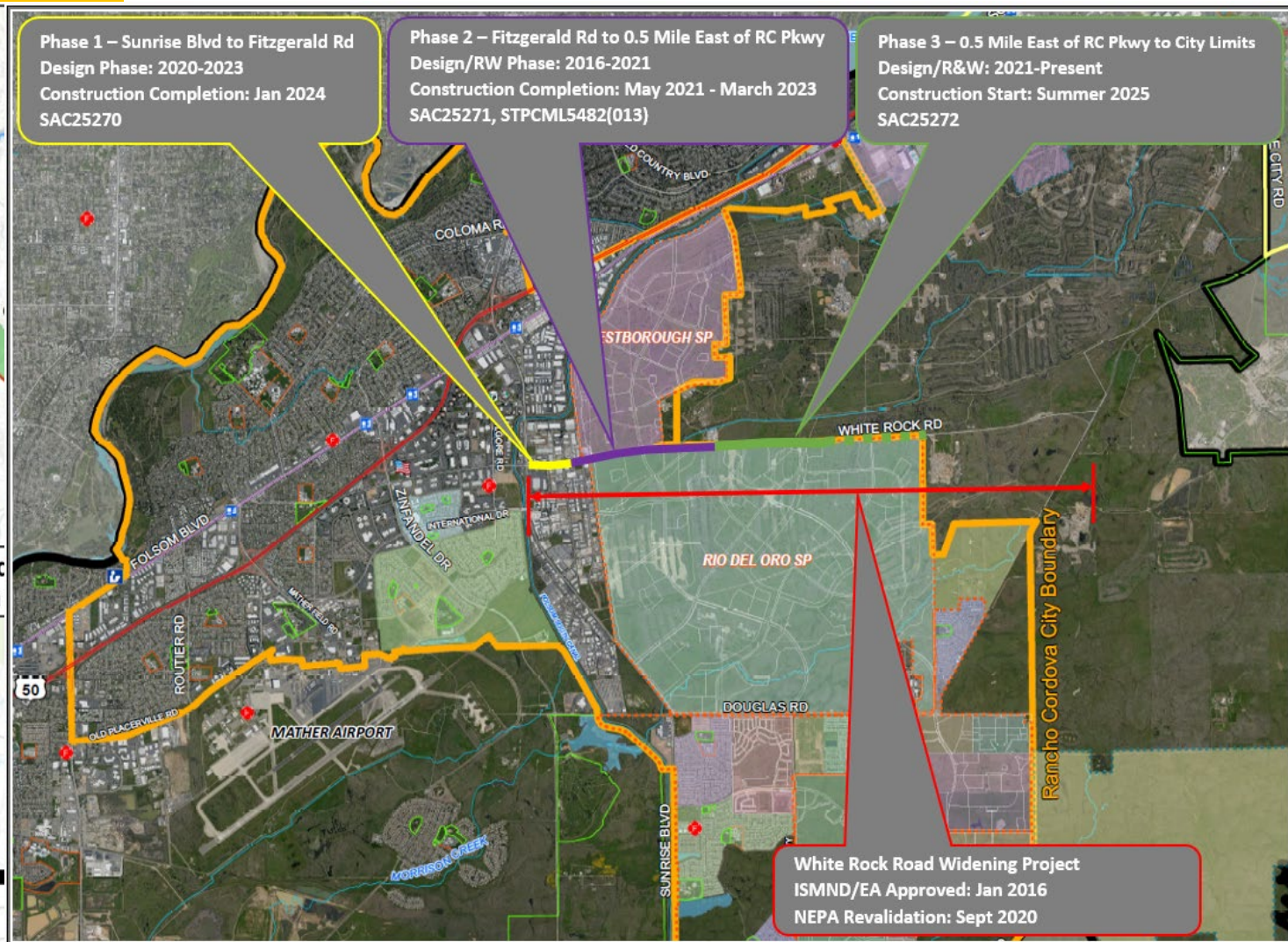
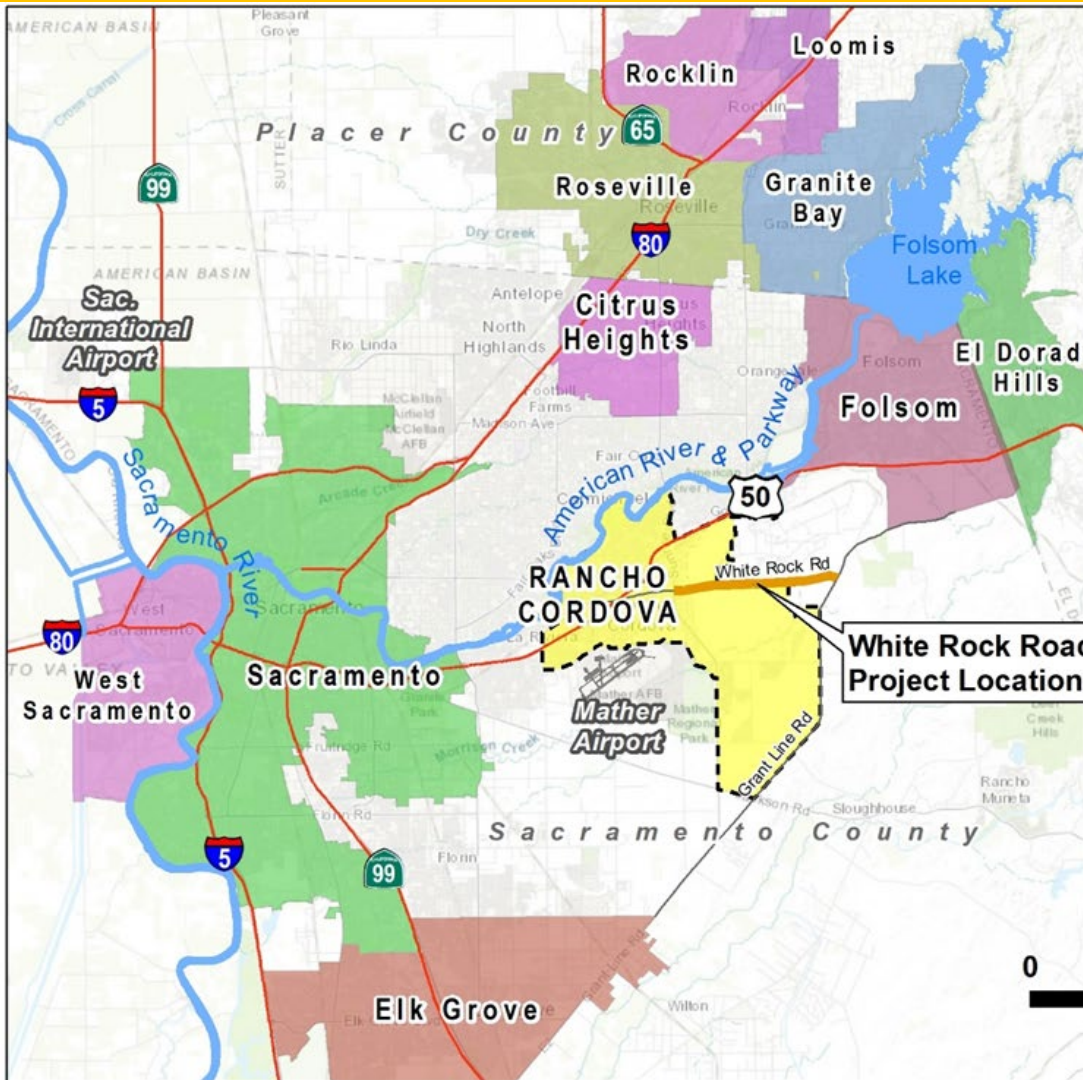

Project Phasing

White Rock Road Project

The Project will:

1. Widen and improve 1.2 miles of two-lane section of roadway to include four realigned lanes;
2. Add Class II bike lanes in each direction that will connect to a future phase
3. Low impact development landscaped median and add drainage facilities.
4. Perform a mill and overlay on 0.8 mile of remaining two-lane to the City/County jurisdictional line.

The Project Benefits will:

- ▶ Provide congestion relief and improve freight and people movement on two segments of the NHS, White Rock Road and US 50, with White Rock Road serving as an alternate route to US 50 during periods of peak congestion or major roadway incidents
- ▶ Replaces a deteriorating segment of White Rock Road.
- ▶ Improves safety on an undivided, horizontally and vertically deficient rural roadway, reducing injuries and fatalities.
- ▶ Provides regional multimodal connectivity
- ▶ Improves an alternative emergency route for first responders and an evacuation route
- ▶ Supports the City and regional economic development and growth plans.
- ▶ Facilitate job growth and housing development close to jobs.

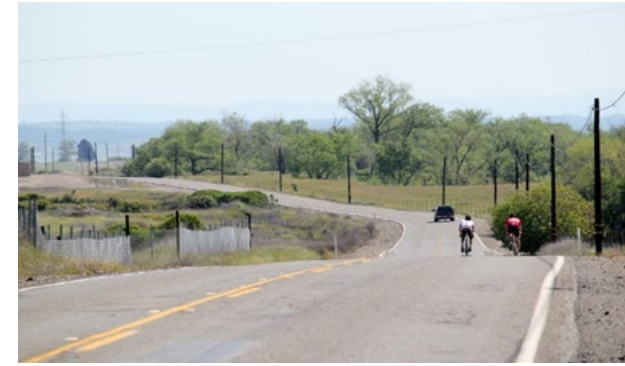

White Rock Road Project

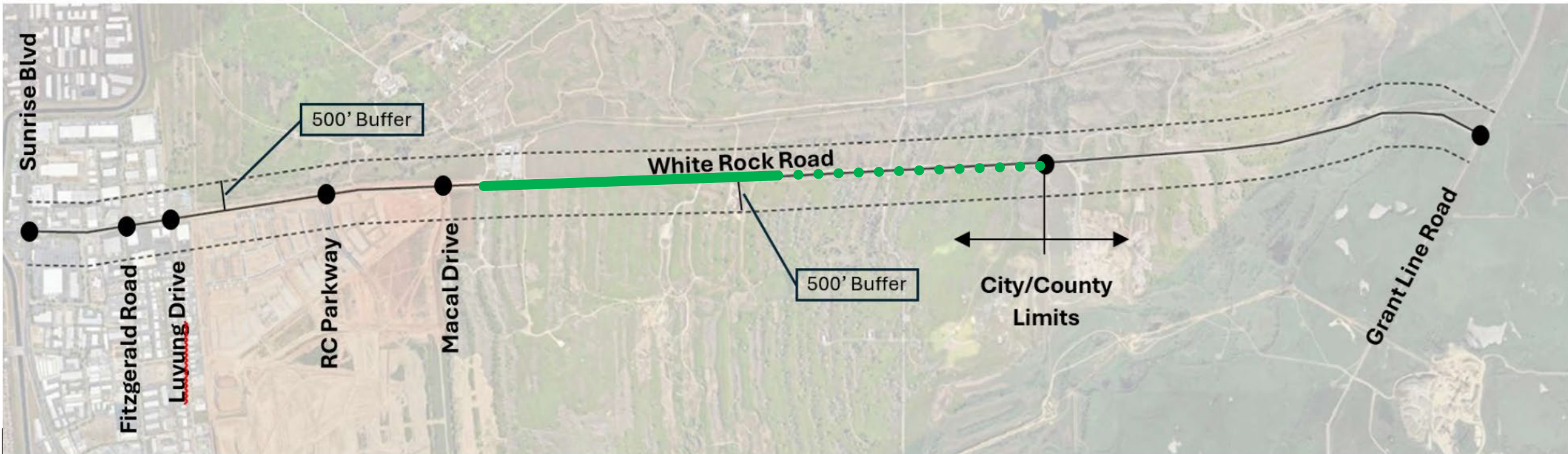
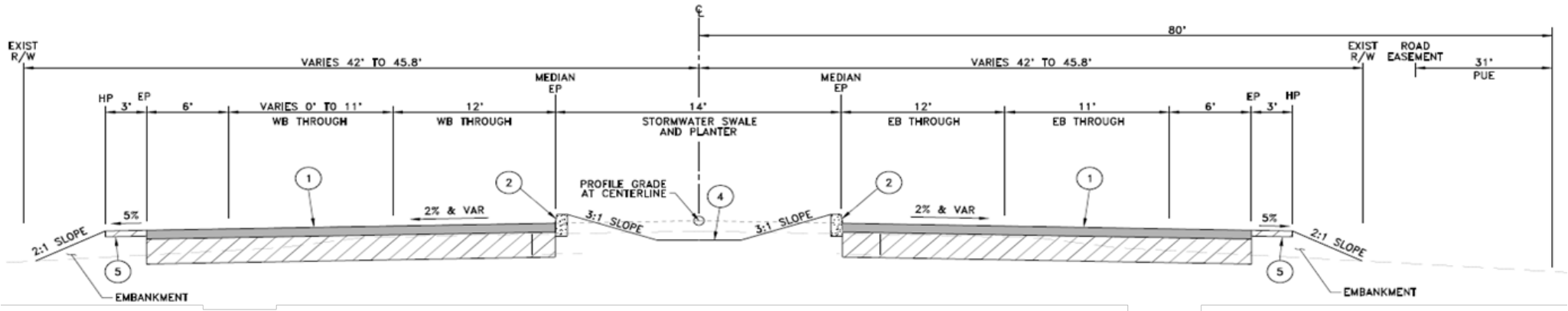

Project Data

White Rock Road Project

Opening Year: Build and No-Build LOS – AM 2-Hr, % and # trucks, truck AM 2-Hr of proposed facility:
(if No Change between Build and N-Build, explain and document why.)

WHITE ROCK ROAD: Sunrise Blvd to Macal Drive (Note: Macal Drive = 0.5 mile east of RC Parkway)

2023	LOS	AADT	AM-2Hr	Truck AADT	Truck AM 2-Hr, % and #
Build	A	10,200	1,260	408	4%, 50
No-Build	A	10,100	1,208	404	4%, 48

WHITE ROCK ROAD: Macal Drive to Grant Line Road (Note: Macal Drive = 0.5 mile east of RC Parkway)

2023	LOS	AADT	AM-2Hr	Truck AADT	Truck AM 2-Hr, % and #
Build	A	4,700	751	188	4%, 30
No-Build	D	4,600	697	184	4%, 28

MTP Horizon Year/Design Year: Build and No-Build LOS, AADT, AM 2-Hr, Truck AADT, and % and # trucks for AM 2-Hr of proposed facility:

WHITE ROCK ROAD: Sunrise Blvd to Macal Drive (Note: Macal Drive = 0.5 mile east of RC Parkway)

2045	LOS	AADT	AM-2Hr	Truck AADT	Truck AM 2-Hr, % and #
Build	C	27,900	4,464	1,116	4%, 179
No-Build	C	27,800	4,405	1,112	4%, 176

WHITE ROCK ROAD: Macal Drive to Grant Line Road (Note: Macal Drive = 0.5 mile east of RC Parkway)

2045	LOS	AADT	AM-2Hr	Truck AADT	Truck AM 2-Hr, % and #
Build	A	9,100	1,825	364	4%, 73
No-Build	E	8,700	1,537	348	4%, 61

Opening Year 2023

Build Out Year 2045

WRR Phase 3 - Summary of Traffic Data

- The project would not result in significantly increased daily truck trips for year 2045 build conditions.
- The highest ADT volume that would occur under 2045 design year conditions is 9,100.
- The highest truck average daily trips that would occur under 2045 design year conditions is 364.
- Intersection level of services are improved from LOS D & E to LOS A in both the 2023 and 2045 year condition.

White Rock Road Project

Previously Approved MTIP			
SACOG ID	SAC25272	SAC	Lead Agency City of Rancho Cordova
Project Title White Rock Rd - .5 Mile East of Rancho Cordova Parkway to Easterly City Limits			
EA Number: n/a	Last Revised	Completion Year	
PPNO: 5604	23-21	2026	
Project Description On White Rock Rd from .5 mile east of Rancho Cordova Parkway to Rio Del Oro Parkway: widen from 2 to 4 lanes, center medians, landscaping, bike lanes, drainage and road construction. Environmental completed for this project under SAC24470.			
	Fed FY	Revenue Source	Engineering Right of Way Construction Total Revenue
	<25		\$110,000 \$500,000 \$4,000,000 \$4,610,000
	2025	Local Agency Funds	
	2025	RIP - STIP AC	\$13,882,000 \$5,500,000 \$5,500,000
			\$110,000 \$500,000 \$23,382,000 \$23,992,000
Federal Project	Total Cost	\$23,992,000	

Environmental – Entire White Rock Corridor	2009-2016
Environmental Revalidation	2020
WRR Phase 2 Project Completion	2023
WRR Phase 1 Project Completion	2024
WRR Phase 3 Final Design	December 2024
Environmental Revalidation (NEPA)	January/February 2025
WRR Phase 3 R/W Certification	February 2025
STIP and Federal Fund Authorizations	April/May 2025
Bid/Award/Construction Start	May/July
Construction Completion	December 2026

Project Schedule

White Rock Rd - .5 Mile East of RC Parkway to Rio Del Oro Parkway

Recommendation

Project maintains determination
that this is NOT a Project
of Air Quality Concern



Review of the Regional Conformity Exemption Status

#	County	MTIP ID	Sponsor	Project Name	Project Description	Expanded Project Description	Project Type
1	SAC	REG18083	Sacramento Regional Transit	Paratransit - Support/Non-Revenue Vehicles	Grouped Projects for Purchase of support vehicles - Projects are consistent with 40 CFR Part 93.126 Exempt Tables 2 and Table 3 categories - Purchase of support vehicles	Replace eight (8) support/non-revenue vehicles that are fourteen (14) years old with new vehicles to allow for Paratransit, Inc. mobility trainers to travel to community training locations and for road supervisors to provide operational services.	Exempt (40 CFR 93.126) - Mass Transit - Purchase of support vehicles
2	SAC	REG18084	Sacramento Regional Transit	Paratransit - Bus Camera Replacements	Grouped Projects for Purchase of operating equipment for vehicles - Projects are consistent with 40 CFR Part 93.126 Exempt Tables 2 and Table 3 categories - Purchase of operating equipment for vehicles (e.g., radios, fareboxes, lifts, etc.)	Acquisition of fifty-eight (58) cameras for the bus fleet of Paratransit Inc.	Exempt (40 CFR 93.127) - Mass Transit - Purchase of operating equipment for vehicles (e.g., radios, fareboxes, lifts, etc.)
3	SAC	REG18082	Sacramento Regional Transit	Paratransit - Bus Stops and Shelters	Grouped Projects for Purchase of office, shop, and operating equipment for existing facilities - Projects are consistent with 40 CFR Part 93.126 Exempt Tables 2 and Table 3 categories - Purchase of office, shop, and operating equipment for existing facilities	Bus stop signage and amenities project to support the People to Produce and Access to Healthcare shuttle program.	Exempt (40 CFR 93.126) - Mass Transit - Purchase of office, shop, and operating equipment for existing facilities.
4	SAC	REG18081	Sacramento Regional Transit	Paratransit - Preventive Maintenance	Grouped Projects for Operating assistance to transit agencies - Projects are consistent with 40 CFR Part 93.126 Exempt Tables 2 and Table 3 categories - Operating assistance to transit agencies.	Paratransit Inc preventive maintenance. FY25: \$200,000 Sec 5307, FY26: \$200,000 Sec 5307	Exempt (40 CFR 93.126) - Mass Transit - Operating assistance to transit agencies
5	SAC	REG18079	Sacramento Regional Transit	Paratransit - People to Produce and Access to Healthcare	Grouped Projects for Operating assistance to transit agencies - Projects are consistent with 40 CFR Part 93.126 Exempt Tables 2 and Table 3 categories - Operating assistance to transit agencies.	Operation of People to Produce and Access to Healthcare shuttle services that integrate into existing RT fixed routes and light rail services to provide first-mile/last-mile connectivity, addressing access gaps for the region's most disadvantaged communities. Sec 5307 for FY25 Service= \$450,000; Sec 5307 for FY26 Service= \$450,000	Exempt (40 CFR 93.126) - Mass Transit - Operating assistance to transit agencies
6	SAC	REG18080	Sacramento Regional Transit	Paratransit - Regional Mobility Management	Grouped Projects for Operating assistance to transit agencies - Projects are consistent with 40 CFR Part 93.126 Exempt Tables 2 and Table 3 categories - Operating assistance to transit agencies.	In the City of Sacramento, multiple locations: Install supportive EV charging infrastructure to catalyze expanded electrification of the City of Sacramento municipal fleet. The project includes construction and installation of Level 2 chargers, DC fast chargers, and electrical infrastructure upgrades at six City locations, to support replacement of light-duty vehicles with EVs, including work trucks.	Exempt (40 CFR 93.126) - Mass Transit - Operating assistance to transit agencies
7	ELD	REG18085	Sacramento Regional Transit	El Dorado County Transit Authority- Bus Replacement	Grouped Projects for Operating assistance to transit agencies - Projects are consistent with 40 CFR Part 93.126 Exempt Tables 2 and Table 3 categories - Operating assistance to transit agencies.	Replace up to 5 minivans that have reached the end of their useful life.	Exempt (40 CFR 93.126) - Mass Transit - Purchase of new buses and rail cars to replace existing vehicles or for minor expansions of the fleet
8	VAR - SAC, YOL, YUB, SUT	VAR56305	SACOG	Paratransit, Inc. Areas of Persistent Poverty Study	Grouped Projects for Planning activities - Projects are consistent with 40 CFR Part 93.126 Exempt Tables 2 and Table 3 categories - Planning activities conducted pursuant to titles 23 and 49 U.S.C.	Feasibility study to assess the potential for operations of semi-fixed route, routine service from Areas of Persistent Poverty in the four-county region to non-emergency medical facilities. Matching funds from USDA LPP (\$25k) and TDA (\$150,000).	Exempt (40 CFR 93.126) - Other - Specific activities which do not involve or lead directly to construction, such as: Planning and technical studies
9	SAC	VAR56306	SACOG	Paratransit, Inc. Innovative Coordinated Access and Mobility Project	Grouped Projects for Planning activities - Projects are consistent with 40 CFR Part 93.126 Exempt Tables 2 and Table 3 categories - Planning activities conducted pursuant to titles 23 and 49 U.S.C.	Paratransit, Inc. was awarded an Innovative Coordinated Access and Mobility (ICAM) grant to make dispatching technology investments focused on real-time coordination and efficient routing. Matching funds will come from Measure A.	Exempt (40 CFR 93.126) - Other - Specific activities which do not involve or lead directly to construction, such as: Planning and technical studies